

QSFP – QSFP 40G Active Optical Cable



Description

The BlueOptics® BO252503KXM QSFP Active Optical Cable is a high performance, cost effective module supporting a data rate up to 40Gbps with 100 Meter link length on multi mode fiber.

BlueOptics® Active Optical Cable are 100% compliant with QSFP Multi-Source Agreement (MSA).

All BlueOptics® QSFP Active Optical Cable are always equipped with digital diagnostic function compliant to MSA SFF-8472.

Using digital diagnostic, BlueOptics® QSFP Active Optical Cable provide the following real time information:

- Supply voltage
- Laser bias current
- Laser average output power
- Laser received input power
- Temperature

Applications

- ✓ 40G Ethernet
- ✓ Fibre Channel
- ✓ Infiniband QDR
- ✓ Data Center

Features

- ✓ 40Gb/s serial optical interface compliant to 802.3bm 40GBASE-SR4
- ✓ Up to 11.1Gbps Data rate per channel
- ✓ VCSEL laser technology
- ✓ Up to 100 Meters
- ✓ Hot-pluggable QSFP footprint compliant to SFF-8431
- ✓ Green Data center: low power dissipation
- ✓ 2-wire interface for management
- ✓ Metal enclosure, for lower EMI
- ✓ RoHS compliant and lead-free
- ✓ Single +3.3V power supply
- ✓ Compliant with SFF-8472

Warnings

Handling Precautions: This device is susceptible to damage as a result of electrostatic discharge (ESD). A static free environment is highly recommended.

Laser Safety: Even small radiation emitted by laser devices can be dangerous to human eyes and lead to permanent eye injuries. Be sure to avoid eye contact with direct or indirect radiation.

Warranty

Every BlueOptics© Active Optical Cable comes with a 5 year replacement warranty and lifetime support. For a warranty inquiry, please contact your CBO sales representative.

This warranty only covers the first user of the equipment.

Important Notice

Performance figures, data and any illustrative material provided in this data sheet are typical and must be specifically confirmed in writing by CBO before they become applicable to any particular order or contract. In accordance with the CBO policy of continuous improvement specifications may change without notice.

The publication of information in this data sheet does not imply freedom from patent or other protective rights of CBO or others.

Further details are available from any CBO sales representative.

Installation

Before installation attach an ESD-preventive wrist to ensure not to damage the Active Optical Cable or hardware.

BlueOptics© BO252503KXM can be installed in any Small Form Factor Pluggable+ (QSFP) port. You can install the BO252503KXM regardless if the system is powered on or off, because it is hot-swappable.

Insert both ends of the Active Optical Cable into the QSFP ports.

You can now use your connection.

Order Information

Part No.	Length	DDM
BO252501KXM	1 Meter	✓
BO252503KXM	3 Meter	✓
BO252505KXM	5 Meter	✓
BO252510KXM	10 Meter	✓
BO252520KXM	20 Meter	✓
BO252530KXM	30 Meter	✓
BO252550KXM	50 Meter	✓
BO2525100KXM	100 Meter	✓

Regulatory Compliance

Feature	Standard	Co.
Electrostatic Discharge (ESD)	- IEC/EN 61000-4- 2	✓
Electromagnetic Interference (EMI)	- FCC Part 15 Class B EN 55022 - Class B (CISPR 22A)	✓
Laser Eye Safety	- FDA 21CFR 1040.10, 1040.11 - IEC/EN 60825-1, 2	Class 1 ✓
Component Recognition	- IEC/EN 60950, UL	✓
RoHS	- 2002/95/EC	✓
EMC	- EN61000-3	✓

1. Absolute Maximum Ratings

Parameter	Symbol	Min.	Typ.	Max.	Unit
Storage Temperature	Ts	-40		85	°C
Storage Ambient Humidity	HA	5		95	%

2. Recommended Operating Conditions

Parameter	Symbol	Min.	Typ.	Max.	Unit	Note
		0		70		BO252503KXM
		-10		80	°C	BO252503KXM
		-40		85		BO252503KXM
Ambient Humidity	HA	5		70	%	
Transmission Distance				100	M	
Coupled Fiber		Multi mode fiber				50/125µm MMF

3. Electrical Interface Characteristics

Parameter	Symbol	Min.	Typ.	Max.	Unit	Note
Power Supply Voltage	Vcc	3.14	3.3	3.46	V	
Signal Input Voltage	Icc			450	mA	
Transmitter						
Input differential impedance	Rin		100		Ω	1
Differential data input swing	Vin,pp		1000		mV	
Single ended input voltage tolerance	VinT	-0.3		4.0	V	
Receiver						
Differential data output swing	Vout,pp	300		800	mV	2
Single-ended output voltage		-0.3		4.0	V	

Notes:

1. AC coupled internally.
2. AC coupled with 100Ω differential termination.

4. High-speed Electrical Characteristics per Lane

Parameter	Symbol	Min.	Typ.	Max.	Unit	Note
Reference Differential Input Impedance	Zd		100		Ω	
Input AC Common Mode Voltage				15	mV	
Termination Mismatch	ΔZM			5	%	
						0.01-4.1 GHz
						4.1 – 11.1 GHz
Jitter Tolerance (Total)	TJ			0.40	UI	
Jitter Tolerance (Deterministic)	DJ			0.15	UI	

5. Maximum Transmitter Input and Receiver Output Differential Return Loss

Parameter	Symbol	Min.	Typ.	Max.	Unit	Note
Reference Differential Input Impedance	Zd		100		Ω	
Input AC Common Mode Voltage				15	mV	
Termination Mismatch	ΔZM			5	%	
						0.01-4.1 GHz
						4.1 – 11.1 GHz
						0.01-2.5 GHz
						2.5-11.1 GHz
Output Rise and Fall time (20% to 80%)	tRH, tFH	24				
Deterministic Jitter	DJOUT			0.38	UI	
Total Jitter	TJOUT			0.64	UI	

6. QSFP to Host Connector Pin Out

Pin	Symbol	Name / Description	Note
1	GND	Transmitter Ground (Common with Receiver Ground)	1
2	Tx2n	Transmitter Inverted Data Input	
3	Tx2p	Transmitter Non-Inverted Data output	
4	GND	Transmitter Ground (Common with Receiver Ground)	1
5	Tx4n	Transmitter Inverted Data Input	
6	Tx4p	Transmitter Non-Inverted Data output	
7	GND	Transmitter Ground (Common with Receiver Ground)	1
8	ModSelL	Module Select	
9	ResetL	Module Reset	
10	VccRx	3.3V Power Supply Receiver	2
11	SCL	2-Wire serial Interface Clock	
12	SDA	2-Wire serial Interface Data	
13	GND	Transmitter Ground (Common with Receiver Ground)	
14	Rx3p	Receiver Non-Inverted Data Output	
15	Rx3n	Receiver Inverted Data Output	
16	GND	Transmitter Ground (Common with Receiver Ground)	1
17	Rx1p	Receiver Non-Inverted Data Output	
18	Rx1n	Receiver Inverted Data Output	
19	GND	Transmitter Ground (Common with Receiver Ground)	1
20	GND	Transmitter Ground (Common with Receiver Ground)	1
21	Rx2n	Receiver Inverted Data Output	
22	Rx2p	Receiver Non-Inverted Data Output	
23	GND	Transmitter Ground (Common with Receiver Ground)	1
24	Rx4n	Receiver Inverted Data Output	1
25	Rx4p	Receiver Non-Inverted Data Output	
26	GND	Transmitter Ground (Common with Receiver Ground)	1
27	ModPrsl	Module Present	
28	IntL	Interrupt	
29	VccTx	3.3V power supply transmitter	2
30	Vcc1	3.3V power supply	2
31	LPMODE	Low Power Mode	
32	GND	Transmitter Ground (Common with Receiver Ground)	1
33	Tx3p	Transmitter Non-Inverted Data Input	
34	Tx3n	Transmitter Inverted Data Output	
35	GND	Transmitter Ground (Common with Receiver Ground)	1
36	Tx1p	Transmitter Non-Inverted Data Input	
37	Tx1n	Transmitter Inverted Data Output	
38	GND	Transmitter Ground (Common with Receiver Ground)	1

Notes:

1. GND is the symbol for signal and supply (power) common for QSFP modules. All are common within the QSFP module and all module voltages are referenced to this potential unless otherwise noted. Connect these directly to the host board signal common ground plane.
2. VccRx, Vcc1 and VccTx are the receiving and transmission power suppliers and shall be applied concurrently. Recommended host board power supply filtering is shown below. Vcc Rx, Vcc1 and Vcc Tx may be internally connected within the QSFP Active Optical Cable module in any combination. The connector pins are each rated for a maximum current of 500mA.

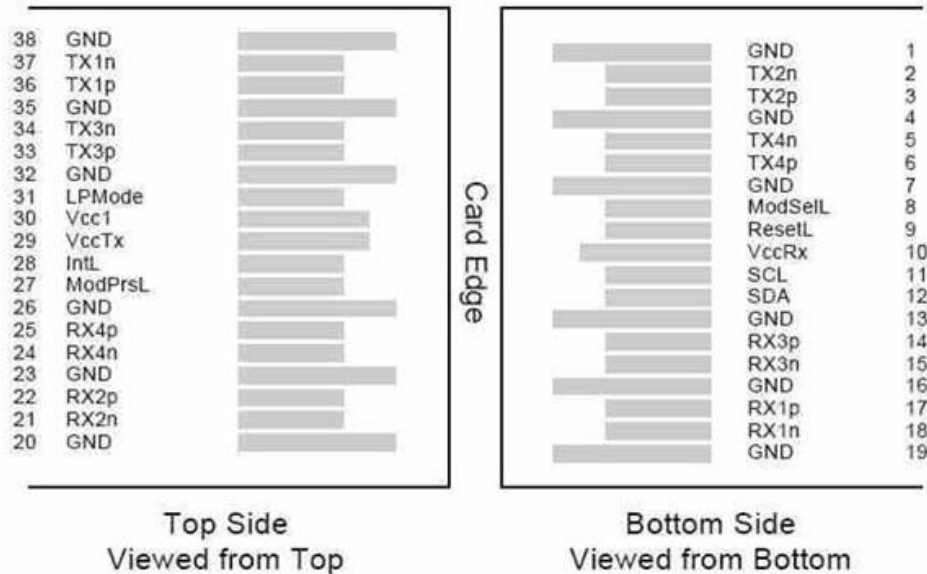

Pinout of Connector Block on Host Board

7. EEPROM Information

The SFP MSA defines a 256-byte memory map in EEPROM describing the Active Optical Cables capabilities, standard interfaces, manufacturer, and other information, which is accessible over a 2 wire serial interface at the 8-bit address 1010000X (A0h).

Data Address	Field Size (Bytes)	Name of Field	Description
128	1	Identifier	Formfactor
129	1	Ext. Identifier	
130	1	Connector	
131-138	8	Transceiver	Transmittter Code
139	1	Encoding	
140	1	BR, Nominal	Transceiver Speed
141	1	Extended RateSelect Compliance	Tags for Extended RateSelect compliance
142	1	Length (9µm) km	Max. link length in KM
143	1	Length (9µm) 100m	Max. link length in M
144	1	Length (50µm) 10m	Max. link length in M
145	1	Length(62.5µm)10m	Max. link length in M
146	1	Length (Copper)	Max. link length in M
147	1	Device Tech	Device technology
148-163	16	Vendor name	Vendor name - OEM
164	1	Extended Transceiver	Extended Transceiver Codes for InfiniBand

165-167	3	Vendor OUI	
168-183	16	Vendor PN	Product Number - depending on Part
184-185	2	Vendor rev	Vendor revision
186-187	2	Wavelength	Transceiver Wavelength
188-189	2	Wavelength tolerance	Guaranteed range of laser wavelength (+/- value) from Nominal wavelength (Wavelength Tol. = value/200 in nm)
190	1	Max Case Temp	Maximum Case Temperature in Degrees C
191	1	CC_BASE	Check code for Base ID Fields (addresses 128-190)
192-195	4	Options	Rate Select, TX Disable, TX Fault, LOS
196-211	16	Vendor SN	Part serial number
212-219	8	Vendor date code	Year, Month, Day
220	1	Diagnostic type	Diagnostics
221	1	Enhanced option	Indicates which optional enhanced features are implemented in the transceiver.
222	1	Reserved	Reserved
223	1	CC_EXT	Check code for the Extended ID Fields (addresses 192-222)
224-255	32	Vendor Specific	Vendor Specific EEPROM

8. Digital Diagnostics / Digital Optical Monitoring

The Active Optical Cable provides serial ID memory contents and diagnostic information about the present operating conditions by the 2-wire serial interface (SCL, SDA).

The diagnostic information with internal calibration or external calibration are all implemented, including received power monitoring, transmitted power monitoring, bias current monitoring, supply voltage monitoring and temperature monitoring.

9. Recommended Interface Circuit

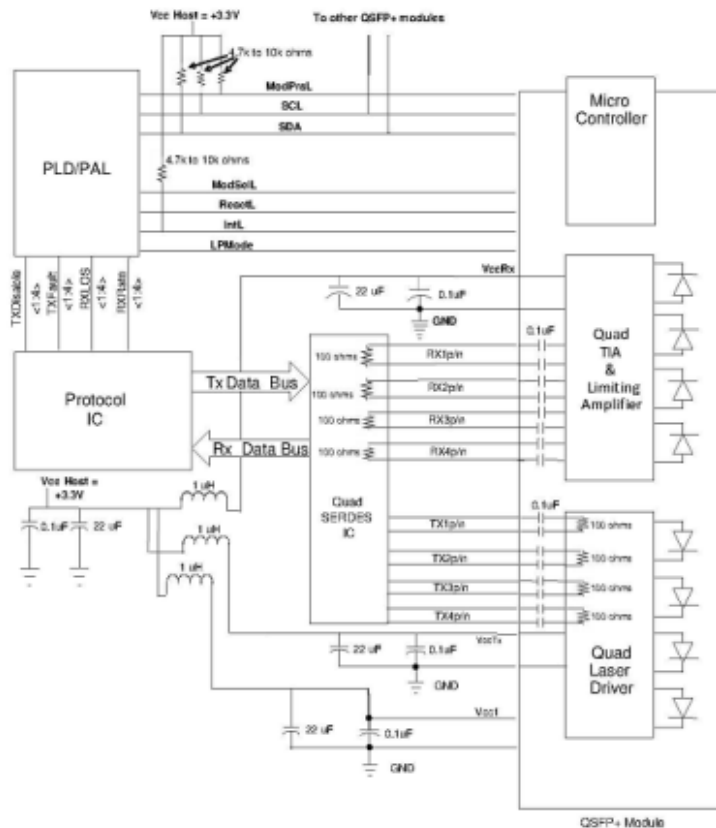

10. Mechanical Specifications (Unit: mm)

